

# SERIES FX V HOT

Permanent magnetic lifters

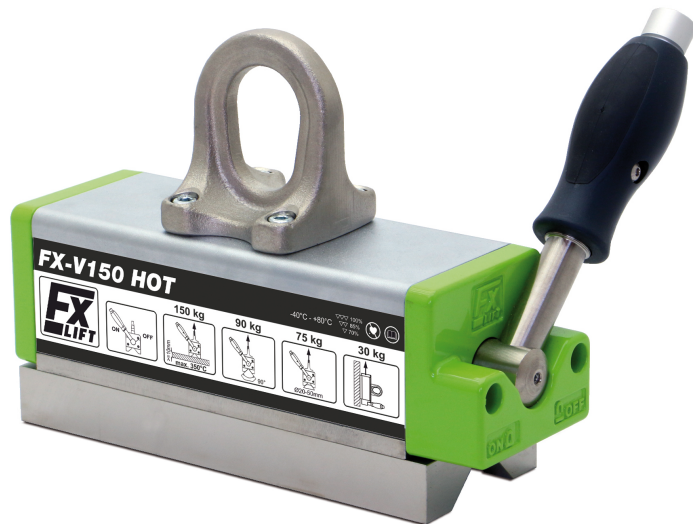

- ✓ Monoblock stator and rotor.
- ✓ 100% nickel plated.
- ✓ Design for beams and profiles
- ✓ 90° prism for lifting curved profiles
- ✓ Suitable for handling hot material up to 350 °C

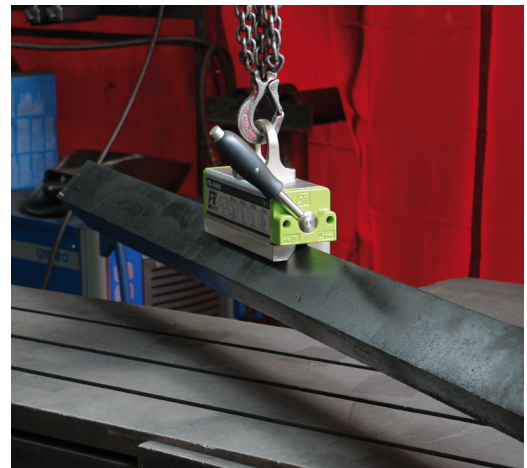
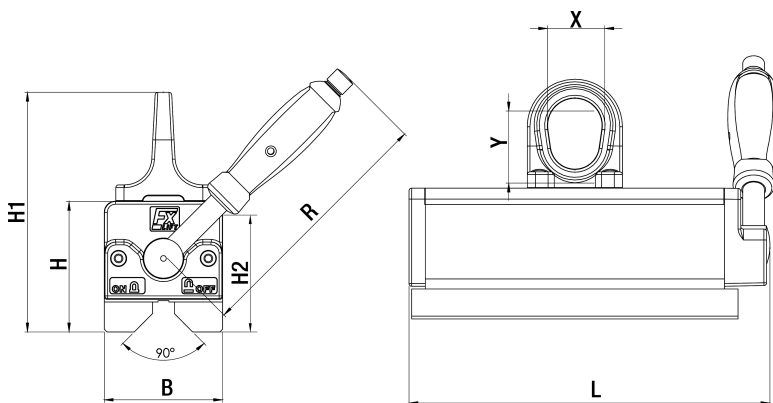

MODEL	Max Contact time 4. Minutes				
	Working Temperature 250°C		Working Temperature 300° C		Working Temperature 350°C
FX V150 HOT	Work Cycle 100% Contac time 100% Capacity	Work Cycle 50% Contac time Max 4. Minutes 50% Cooling time Min 4. Minutes	85% Capacity 125 kg	Work Cycle 33% Contac time Max 4. Minutes 66% Cooling time Min 8. Minutes	75% Capacity 110 kg
FX V300 HOT			85% Capacity 255 kg		75% Capacity 225 kg
FX V600 HOT			85% Capacity 510 kg		75% Capacity 450 kg

MODEL	MAX LOAD CAPACITY (kg)		MAX LOAD CAPACITY FROM (mm)	DIMENSIONS (mm)						WEIGHT kg
	FLAT	ROUND		L	B	H	H1	R	X/Y	
FX V150 HOT	150	diam 20-50 mm 75 kg	10	195	64	77	141	134	30/42	5.5
FX V300 HOT	300	diam 25-60 mm 150 kg	15	263	87	96	176	188	42/53	13
FX V600 HOT	600	diam 35-75 mm 300 kg	20	348	112	115	210	228	51/62	28

Safety Factor 3.5 - Test Method EN 13155 - max. Operation temperature 250°C / 100%