

SERIE FX P

Sollevatori a magneti permanenti

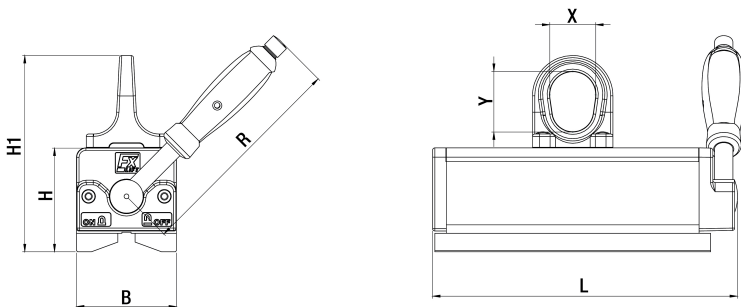

- ✓ Statore e rotore monoblocco.
- ✓ 100% nichelato.
- ✓ Specifico per materiali sottili.
- ✓ Indicato per la movimentazione di tubi e profilati.



MODELLO	MAX CAPACITA' DI CARICO PER LASTRE E TUBI QUADRI (portata in kg per spessore in mm)						L x B Max. (mm)	TUBI Diametri consentiti	Portata(kg)/ spessore (mm)
	3 mm	4 mm	6 mm	8 mm	10 mm	15 mm			
FX P170	50	80	120	170	170	170	2000 x 1250	diam 30-105 mm	150/8mm
FX P330	70	100	160	300	330	330	2500 x 1250	diam 40-160 mm	300/10mm
FX P650	100	160	200	450	530	650	3000 x 1500	diam 60-210 mm	550/20mm

MODELLO	MAX CPACITA' DI CARICO (kg)		MAX CAPACITA' DI CARICO DA (mm)	DIMENSIONI (mm)						PESO kg
	PIANO	TONDO		L	B	H	H1	R	X/Y	
FX P170	170	diam 30-105 mm 150 kg	8	195	64	70	134	136	30/42	5.1
FX P330	330	diam 40-160 mm 300 kg	10	265	87	90	170	190	42/53	12.4
FX P650	650	diam 60-210 mm 550 kg	20	352	112	106	203	228	51/62	26

Fattore di sicurezza 3.5 Test Method EN 13155 max. temperatura di esercizio 80°C