

# SERIES MW22 RECTANGULAR

Electromagnets for steel scraps



- ✓ Suitable for cast ingots, steel balls, cast iron, machine shavings, for various types of steel scraps, return scraps, trimming, pressing scraps and so on.
- ✓ Voltage DC -220V  
Duty cycle TD 60%

The most used series has a rectangular shape, particularly suitable for lifting and transporting billets, steel ingots, round shapes, profiles etc.

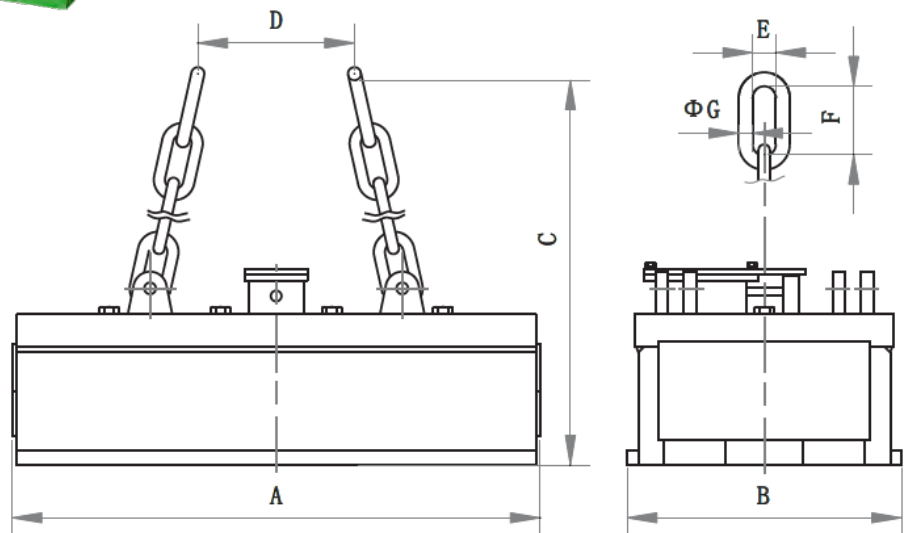

MODEL	Cold state Power kW	Current A	DIMENSIONS (mm)						Lifting Capacity (Ingolts) pezzi	Weight kg
			A	B	C	D	E	G		
MW22 9065L	4,85	22	900	650	1050	500	110	35	5 - 11m	1420
MW22 11065L	5,6	25,5	1100	650	1050	500	110	40	6 - 11m	1720
MW22 14065L	6,9	31,3	1400	650	1100	600	125	45	8 - 11m	2150
MW22 17065L	8,1	36,5	1700	650	1200	600	125	50	10 - 11m	2650
MW22 21065L	10,1	45,7	2100	650	1250	700	140	55	12 - 11m	3110
MW22 11070L	5,6	25,5	1100	700	1050	500	110	40	6 - 12m	1860
MW22 14070L	6,9	31,3	1400	700	1100	600	125	45	8 - 12m	2330
Other models on request										